



## 19.6W Power over Ethernet Adapter DC Input Single Port Injector



### Features

Detection and Classification per IEEE802.3af	Full Protection OCP, OVP
Diagnostic LEDs	Gigabit Compatible
Non-Vented Case	1 Year Warranty
DC Input Voltage 18-72VDC	Lowest cost DC Input Power Injector

### Applications

IP Telephones	Security Cameras
Wireless Network Access Points	IP Print Servers
Blue Tooth Access Point	

### Safety Approvals

CE

### Mechanical Characteristics

Length: 140mm (5.51in)	Height: 36mm (1.42in)
Width: 65mm (2.55in)	Weight: 0.2Kg (0.44lb.)

### Output Specifications

Model	DC Output Voltage	Load		Regulation	
		Min.	Max.	Line	Load
POE20D-1AF-R <sup>1</sup>	56V	0A	0.35A	54-57Vdc under all conditions	

Notes: (1) Consult factory for availability

## POE20D – 1AF Characteristics

### INPUT:

#### DC Input Voltage Range

18 to 72VDC

#### DC Input Current

1.5A for 18V DC and maximum load

### OUTPUT:

#### Total Output Power

19.6W at 56VDC

#### DC Offset

No data degradation with DC imbalance 18mA

#### Efficiency

80% at maximum load (>36 to 72VDC)

75% at maximum load(18 to <36VDC)

#### Ripple and Regulation

100mV maximum at ambient 25°C

#### Transient O/P Voltage Protection

60V maximum at switch on and off

### ENVIRONMENTAL:

#### Temperature

Operation -20 to +50°C

Non-operation -25 to +85°C

Humidity 5 to 90%

#### EMC

Complies with FCC Part 15 Class B

Complies with EN55032 Class B

#### Isolation Test

Primary to Secondary: 2121VDC for 1 minute, 10mA

Primary to Field Ground: 2121VDC for 1 minute, 10mA

Output to Field Ground: 2121VDC for 1 minute, 10mA

### Immunity

ESD: EN61000-4-2. Level 3

RS: EN61000-4-3. Level 3

EFT: EN61000-4-4. Level 2

Surge: EN61000-4-5. Level 3

CS: EN61000-4-6. Level 3

Voltage Dips EN61000-4-11

Harmonic: EN61000-3-2

### Insulation Resistance

Primary to Secondary: >10M OHM 500VDC

Primary to Field Ground: >10M OHM 500VDC

### FEATURES:

#### Over Voltage/Current, Short Circuit Protection

Outputs equipped with short circuit protection and overload protection as per 802.3af specification

The output can be shorted permanently without damage

#### Indicators

Green LED 1: Input power "ON"

Red LED: Fault detected

Green LED 2: Valid IEEE802.3af load detected and connected

#### Input Connector

– Anytek OQ0355510000G

Mate – Anytek TJ0350520000G or

TJ0351520000G

Anytek is part of Giga-Way Technology Corp

#### Output Connection

+pins 3, 6

-pins 1, 2

#### Warranty

1 Year

**Dimension Diagram Unit: mm (inch)**

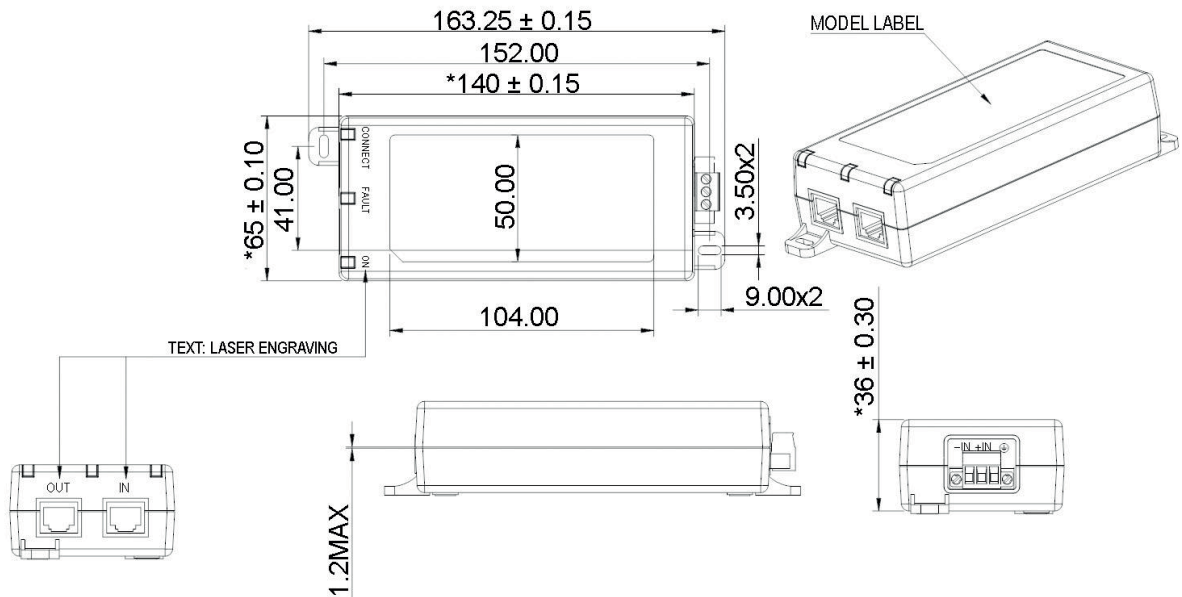

**Gigabit Power Injector Block Diagram**

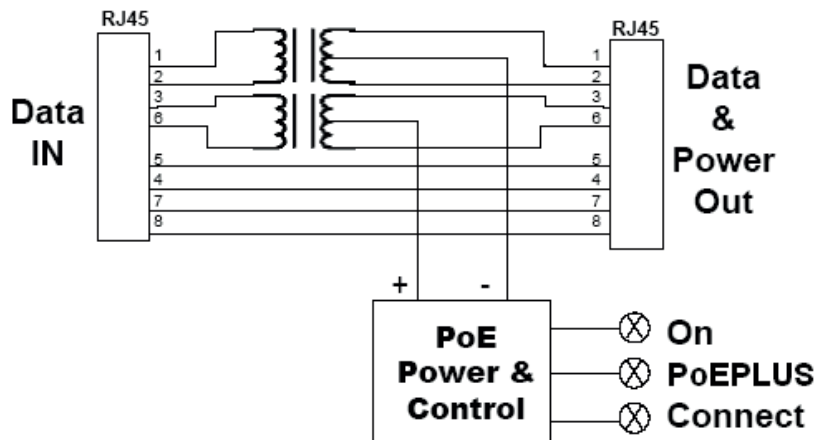

**Description of LED Functions for Gigabit Power Injector**

**Power-up Sequence:**

Upon power-up, all 3 LEDs will light for 2 seconds, as part of the self-test for the internal microprocessor software. After the end of the 2 seconds, the "ON" LED will illuminate green, signifying that the DC output voltage is available for powering a compliant load (to the 802.3af PoE standards).

### **Detection Sequence:**

Once a compliant load is attached to the output RJ45 connector, the green "CONNECT" LED will illuminate.

Should the load be non-compliant then the LEDs will blink a code signifying the cause for non-detection.

### **Detection Failure Codes:**

1. Incorrect resistive signature – The green "CONNECT" and red "FAULT" LEDs will blink 3 times.
2. Incorrect capacitive signature – The green "ON" LED will blink 3 times.
3. Incorrect Voffset – The green "CONNECT" and green "ON" LEDs will blink 3 times.
4. Unstable current measurement – The green "ON" LED will blink 3 times
5. Low voltage sensed during detection (overload) – The red "FAULT" LED will blink 3 times

After the LEDs blink 3 times the Power Injector will continue to try to detect a valid load. Therefore, until the correct load is applied, the LEDs will continue to blink. If there is an open circuit connected to the output RJ45 then the LEDs will not blink but the Power Injector will continue to try to detect a valid load.

### **Fault Sequence:**

Should there be a fault such as an overload or short circuit then the red "FAULT" LED will illuminate. The red "FAULT" LED will illuminate for 2 seconds and then go off as the power supply tries to redetect a valid load. If there is a problem in detecting, the LED will indicate what is wrong with the load as per the codes in the section above.